

## Section 1: Description

The corner step is installed in a corner of the pool to allow one to enter and exit the pool more easily by providing a step between the pool coping and the interior return channels. This corner step will fit into any of the four corners of the pool. Steps are best ordered prior to shipment by contacting your salesperson. The orientation can be determined later. They may also be ordered after the pool has been shipped by contacting our Customer Service Department.

## Section 2: Installation

The dimensions of the corner step cause it to rest on the front or rear base (depending on where it is being installed) and the side return channels. There are circumstances that make the front and/or rear base to not be planar with the side return channels. A cosmetic filler piece has been provided to fill any gap underneath the corner step for this condition. If the front or rear base and the side return channels are planar, then this filler piece can be discarded.

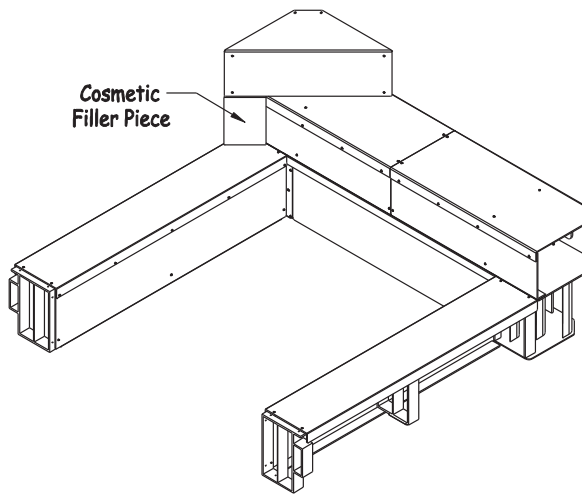

Non-Planar Installation

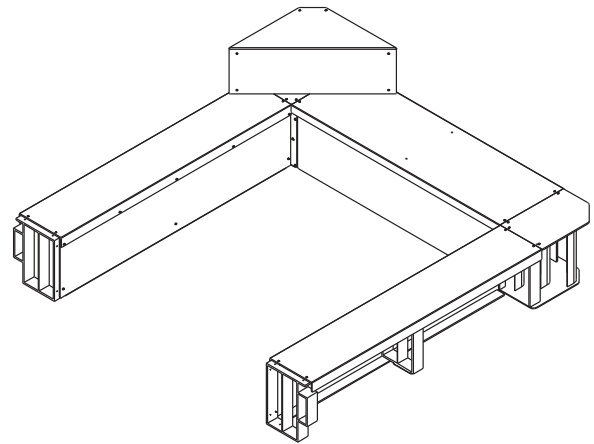

Planar Installation

### Instructions for Installing the Corner Step on a Non-Planar Surface

1. If installing on a rear bench seat, then assemble the rear bench seat as instructed in the, "Rear Bench Seat for 48" & 54" Pool" Supplemental Guide.
2. Remove the 6 screws from the corner step, which hold the cover in place. Be careful not to allow the sharper edges of the step cover to come into contact with the liner as a hole may result.

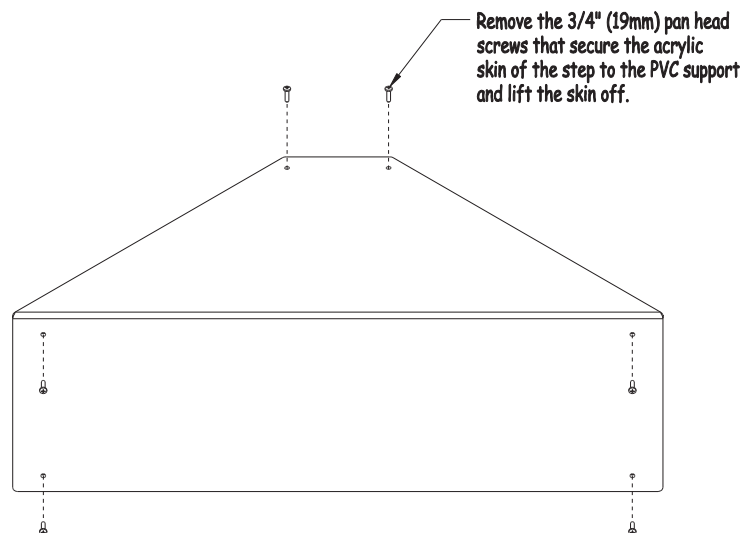

- The corner step will extend beyond the front face of the rear bench seat. A cosmetic filler piece has been provided to fill the gap between the underside of the corner step and the water return channels. The filler piece may need to be modified to fit depending on the application in which it is being used. There is a snap-line etched in its back face. Use the diagram below to determine where the filler piece needs to be modified (if installing the corner step onto a 12" tall rear bench seat, then the filler piece does not need to be modified).

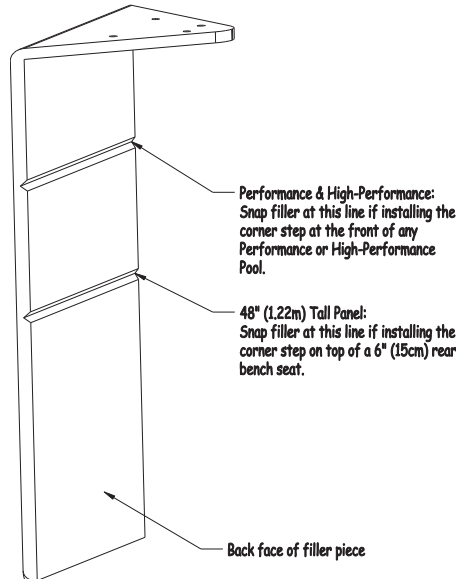

- There are several clearance holes in the base of the PVC corner step. Existing screws may be positioned inside some of these clearance holes. Use the 11/64" drill bit provided with the rear bench seat hardware kit to drill a minimum of two holes into the surface upon which the step rests through these clearance holes. Secure the corner step to the rear bench seat, using one of the long screws and fender washer, provided with the corner step.

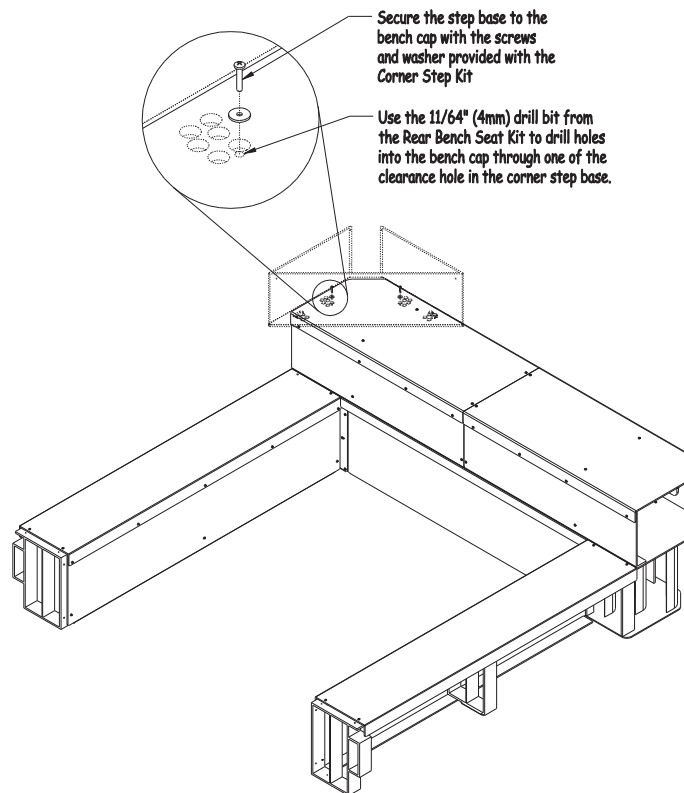

- Place the filler piece into the gap so that the pre-drilled hole in the filler aligns with the hole in the base of the step. Use the provided screw and fender washer to attach.

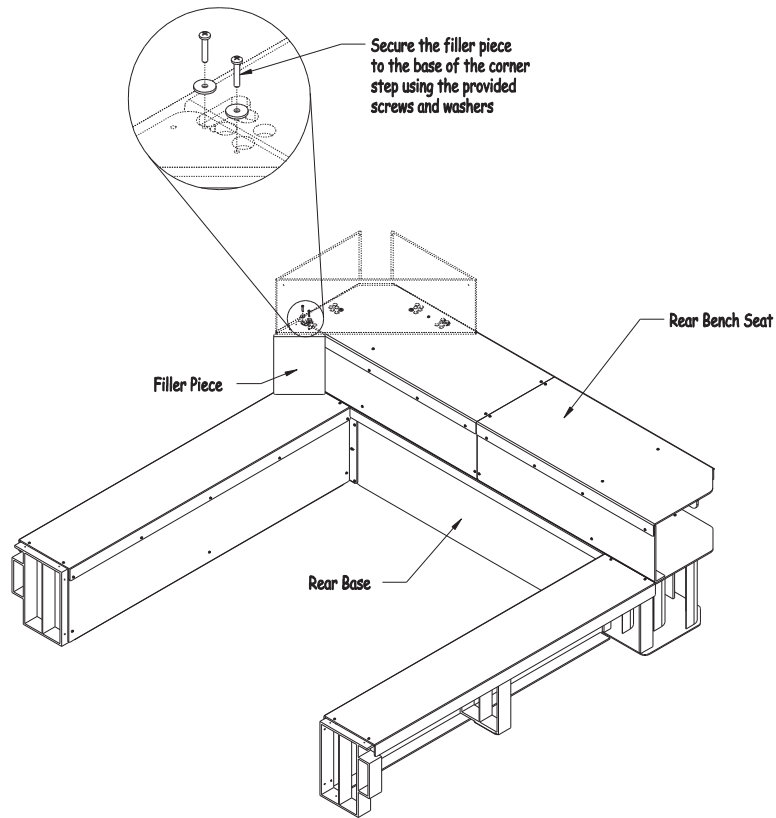

- Reattach the cover to your step and replace all 6 screws.

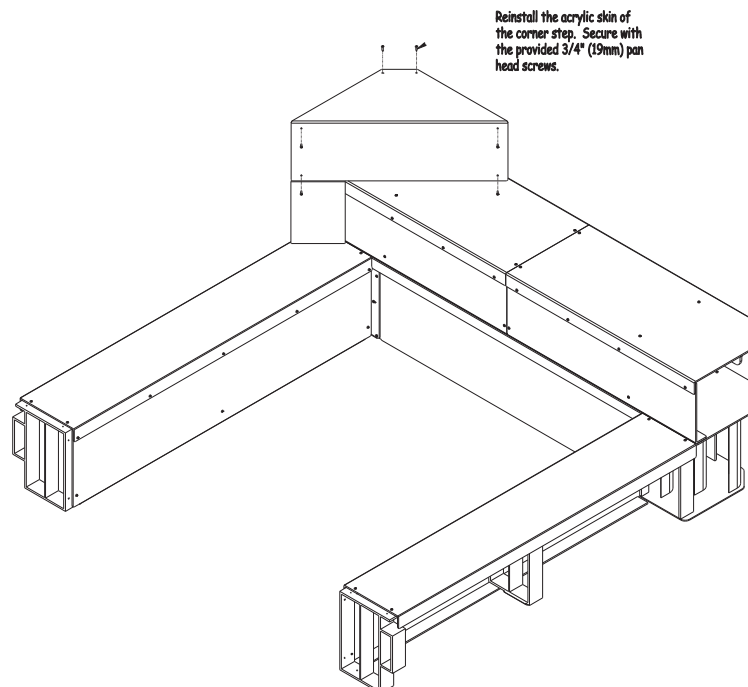

**Instructions for Installing the Corner Step on a Planar Surface**

1. Remove the 6 screws from the corner step, which hold the cover in place. Be careful not to allow the sharper edges of the step cover to come into contact with the liner as a hole may result. Note: inside of the corner step, there is a decorative filler piece; it is not used in this application.

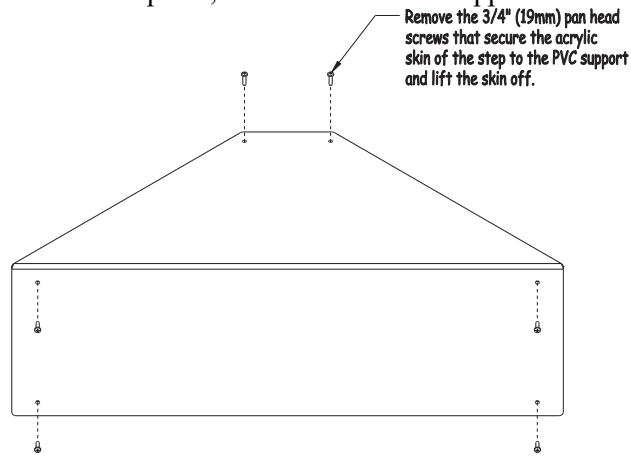

2. There are several clearance holes in the base of the PVC corner step. These holes give you the option to put the step in any of the four corners of the pool. Only four of these holes will be used. Place the step without the cover in the corner of the pool you desire. The holes will align with the screws in the bench and corner cover. Remove the two screws in the benches and replace them with the longer screws and fender washers provided. This will secure your new corner step.

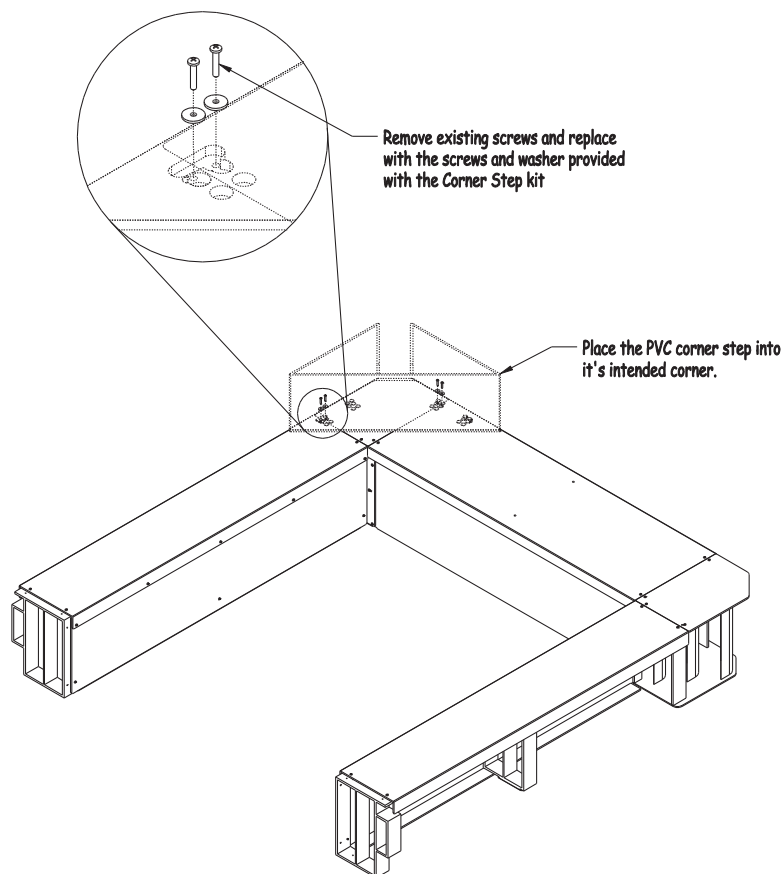

3. Reattach the cover to your step and replace all 6 screws.

4. An anti-slip SwimDek pad is provided with the corner step kit and is designed to adhere to the surface area of the step. **The anti-slip pad MUST be installed prior to filling the pool past the level of the step. The surface area of the step MUST be completely dry prior to adhering the pad.**

Refer to the **SwimDek Supplemental Guide** for instructions on adhering the anti-slip pad to the corner step.